

Vision Hema[®] 4Pro

Blood cell image analysis

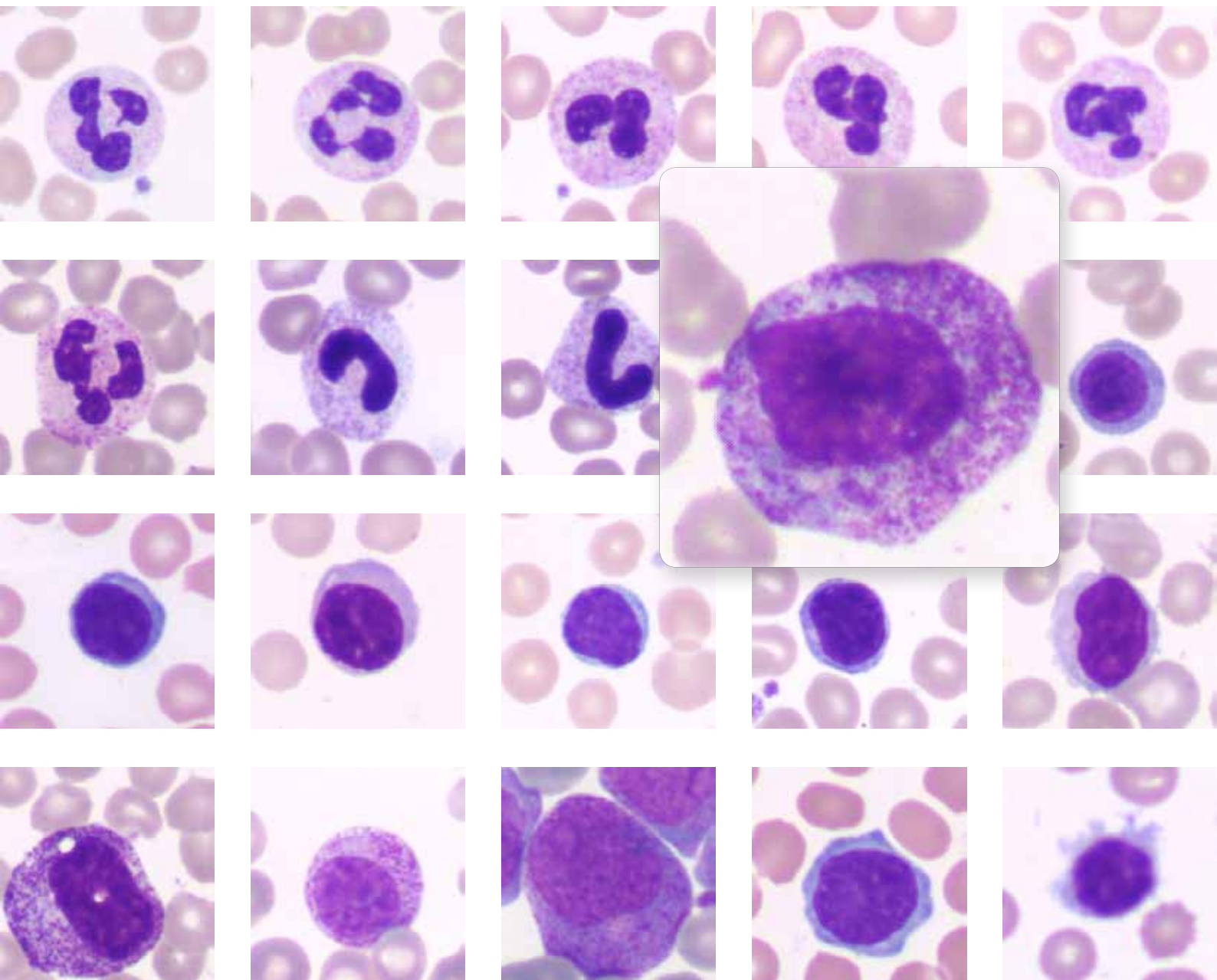

Cost-effective and professional solution for hematology laboratory

Workflow automation and standardization. Improved quality and increased productivity. Time efficiency.

Combination of innovative technology and classical microscopy extends working possibilities

Reduction in routine workload on qualified personnel significantly facilitates the work of the entire laboratory

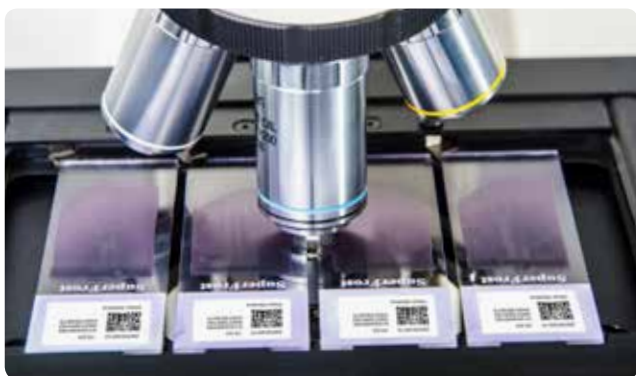

Loading 4 slides simultaneously

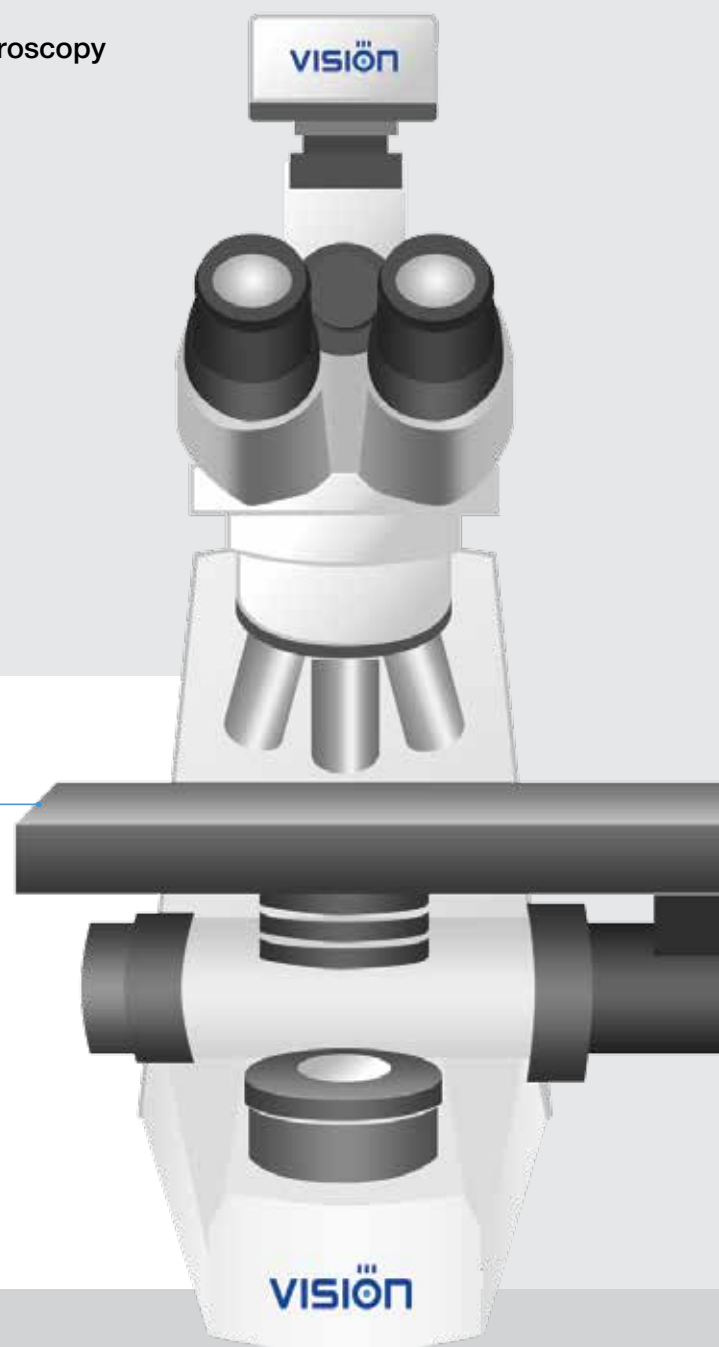

Reliability and objectivity, confirmed by documentation

Automatic scanning. Identification and pre-classification of blood cells.
Quick validation of results. Morphological analysis.

Basic working tools for managing analysis results

Blood cells are placed in a gallery and are organized into groups

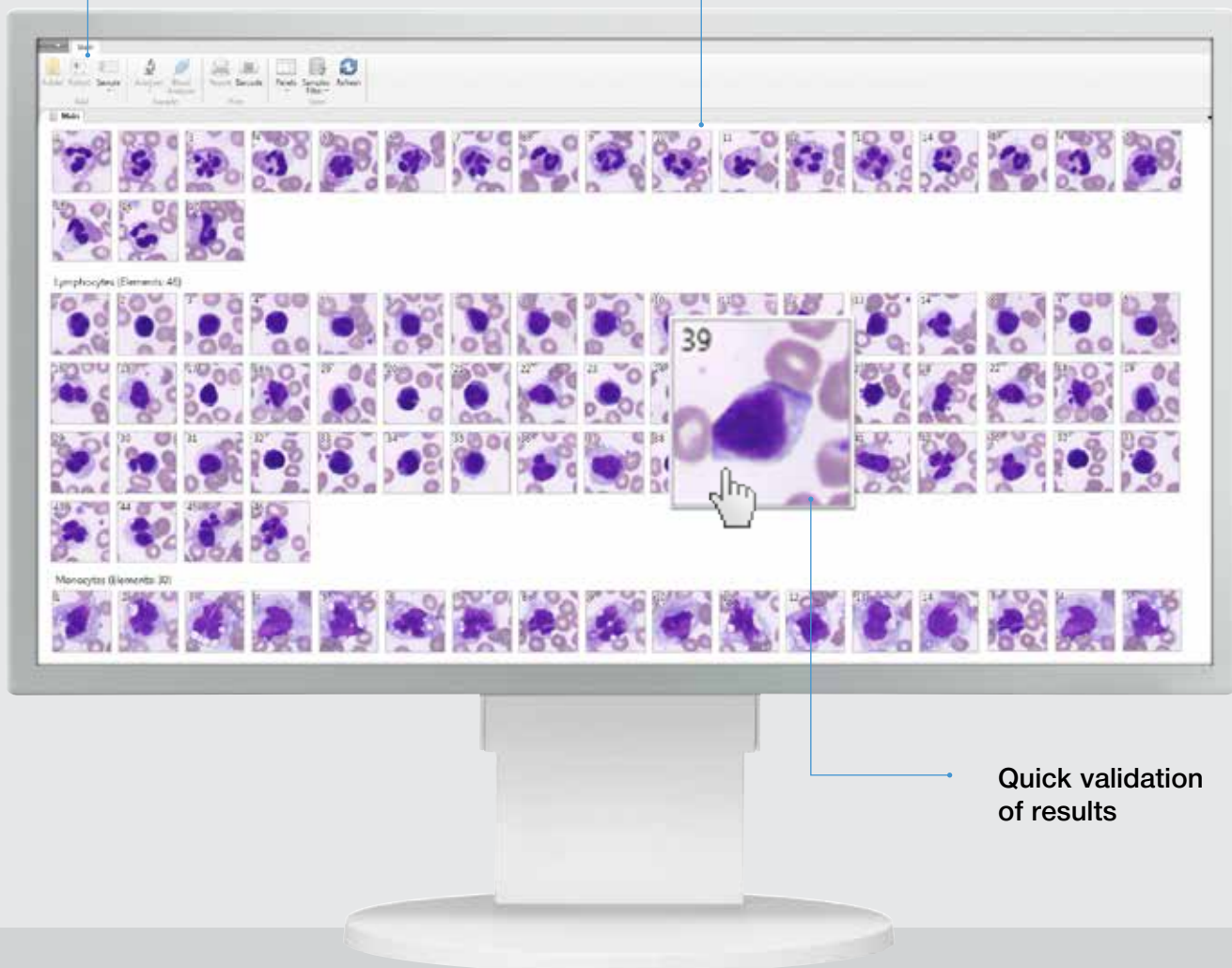

Optimal solution for laboratories

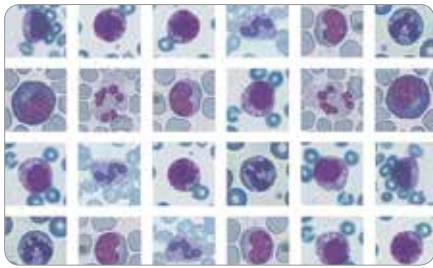

Scanning, identification and pre-classification

Vision Hema® automatically scans a microscopic sample, collects data for analysis, sorts blood cells and saves the results in the database.

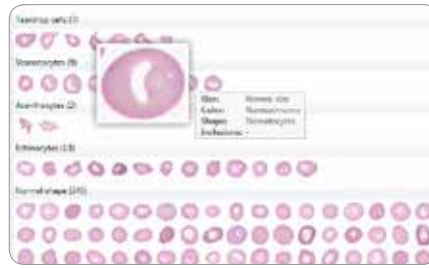

Validation of WBC, RBC and platelets

The specialist is free from routine monotonous work. Analysis results are displayed in galleries of cells and arranged in groups. All you need to do is to review and verify the results.

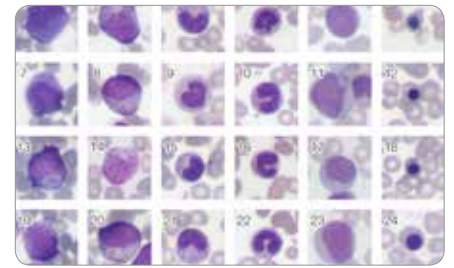

Solution for difficult cases with pathological blood cells

Pre-classification by types of leucocyte and identification of immature and atypical shapes of blood cells including blasts; pre-classification of normoblasts and other non-WBC cells.

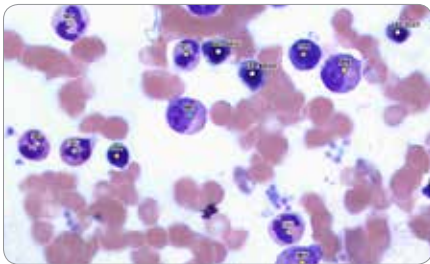

Additional features

Vision Hema® Extended RBC
Detailed analysis of erythrocytes.

Vision Hema® Bone Marrow
Analysis of bone marrow cells.

Vision Hema® RET
Identification and pre-classification of reticulocytes.

Vision Hema® Malaria
Analysis of Malaria.

Vision Hema® Body Fluids
Cell morphology in human body fluids.



Solutions and network capabilities

Vision Hema® Integro
Integration with a hematology analyzer.

Vision Hema® Manager
Standardization of blood smear analysis procedure.

Vision Hema® Remote
Remote access to analysis results.

Vision Hema® Network
Unified information environment.



Competence evaluation and training of specialists

Vision Hema® Expertise
Online testing.
Quality control and training of specialists.

* Product images are shown for reference only and final product may differ

